

LOW SPEED KIT

MFG. NO. 1690047 LOW SPEED KIT

OPERATOR'S MANUAL

LOW SPEED KIT (MFG. NO. 1690047)

The low speed kit has a larger pulley, which allows higher engine rpm at a slower forward travel. It is used on a 3-speed manual transmission tractors and is advantageous when using a snow thrower, tiller, dozer or grader blade. See Figure 1.

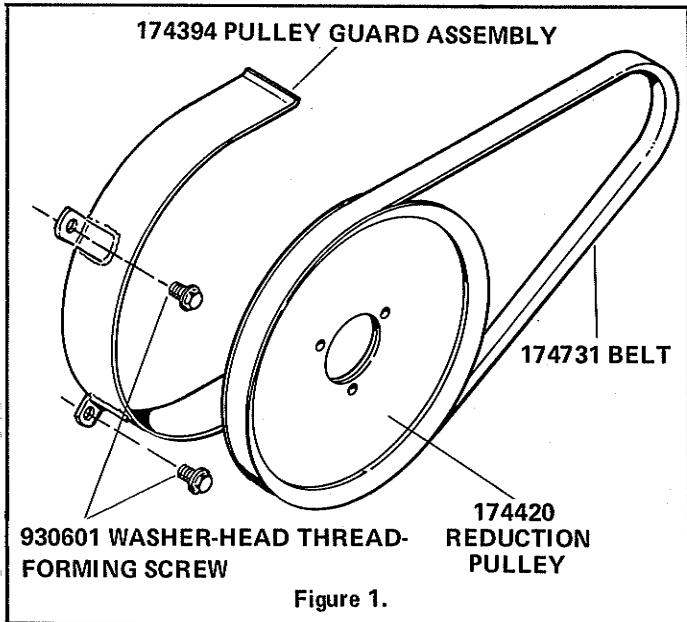

Remove standard pulley and belt as follows:

1. See Figure 2. Fully depress the brake/clutch pedal to the full "brake" position. Secure the pedal in this position by tying a rope around the pedal and the front axle.

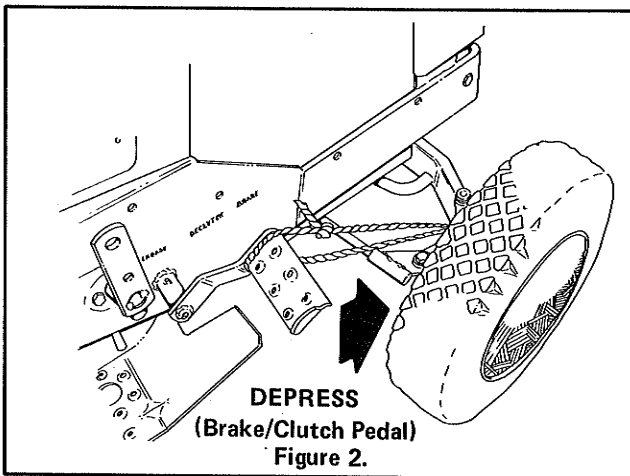

2. See Figure 3. Raise the seat deck by pushing up on the seat latches located under the front edge of the seat deck. There are two latches, one on each side of the seat deck.

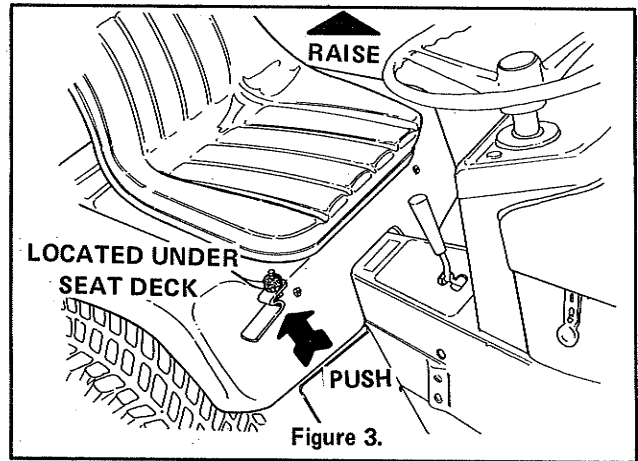

3. See Figure 4. Loosen front belt guard mounting bolt and shift front belt guard forward.
4. See Figure 4. Remove original belt.
5. See Figure 4. Remove three standard rear pulley cap screws and lockwashers. Remove standard pulley.

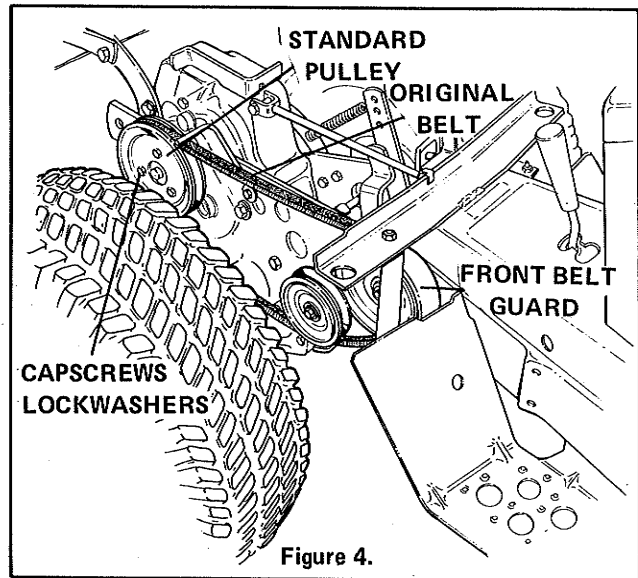

Install low speed kit as follows (See Figure 5):

1. Secure reduction pulley to hub pulley with three standard cap screws and lockwashers.
2. Install new belt and attach new rear belt guard with two washer-head thread-forming screws. The belt guard is attached through two factory drilled holes in seat support.
3. Adjust rear wire belt guide to original 1/4-inch spacing and front belt guard to 1/8-inch spacing.

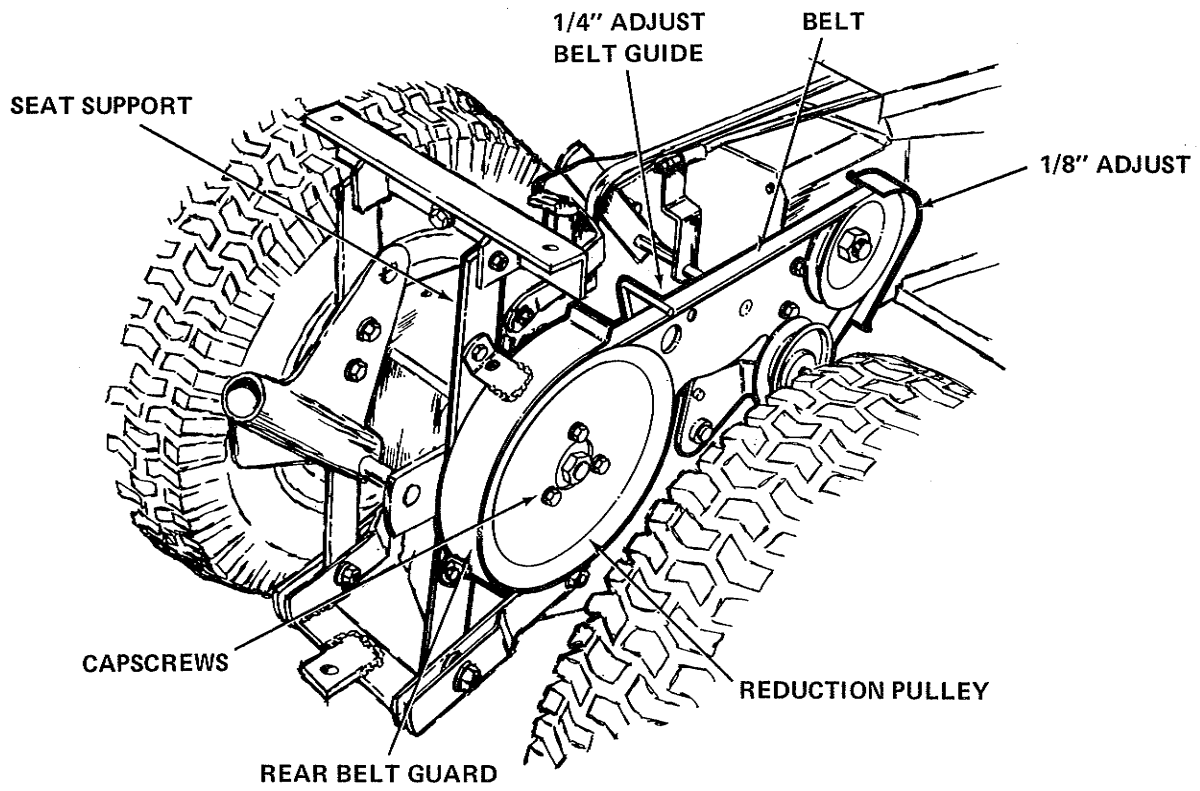

Figure 5.

